



Leading the way in hazardous area static control



Grounding & Bonding Applications Issue 8

Controlling Static Electricity
in Hazardous Areas

www.newson-gale.com

Controlling Static Electricity in Hazardous Areas

Page Contents

- 3 Effective Control of Static Electricity through Grounding and Bonding
- 6 International Standards for Controlling the Hazards of Static Electricity in Potentially Combustible Atmospheres
- 7 Grounding and Bonding Equipment Solutions
- 8 Application Drawings
The Last Hurdle - The Resistance to True Earth
- 9 Grounding a Road Tanker Truck
Using a tanker ground monitoring / interlock system
- 10 Grounding Rail Cars
Using the Earth-Rite PLUS
- 11 Grounding Service Vehicles / Vacuum Trucks
Using a Mobile Static Ground Verification system
- 12 Grounding of Mixing / Blending / Filling Machines
Using Earth-Rite TELLUS
- 13 Grounding Flexible and Rigid IBCs
Using appropriate ground monitoring / interlock systems
- 14 Grounding Interconnected Plant Items, Pipes and Ducting
Using a multi-channel ground monitoring / interlock system
- 15 Grounding a Fluid Bed Drier and its Components
Using a multi-channel ground monitoring / interlock system
- 16 Grounding Rotating Vessel and Fixed Container
Using dedicated ground monitoring / interlock modules
- 17 Grounding Drums and Containers
Using self-testing clamps and cables
- 18 Grounding Drums in a Drum Store or Processing Room
Using line voltage / mains powered self-testing clamps and cables

Page Contents

- 19 Grounding Mobile Vessels and Small Containers
Using self-testing clamps and cables
- 20 "Trans-Loading" Road Tanker/Railcar transfers to IBC/Tote/Drum
Using a ground monitoring system and portable bonding assembly
- 21 Grounding Drums and Containers
Using hazardous area approved grounding clamps and cables
- 22 Grounding Drums and Containers with Storage Rack
Using hazardous area approved grounding clamps and cables
- 23 Bonding and Grounding Mobile Vessels and Small Containers
Using hazardous area approved grounding clamps and cables
- 24 Grounding IBCs and Containers
Using hazardous area approved grounding clamps and reels
- 25 Grounding Personnel and Testing Condition of Footwear
Using static-dissipative footwear / footwear tester
- 26 Guide to protection concepts and codes for electrical equipment operating in hazardous areas. Temperature Classification of electrical equipment.
- 27 Comparison of European (ATEX), North American (NEC & CEC) and International (IECEx) Hazardous Area Classification Systems
Comparison of European and North American Gas (and Dust) Groups
Ingress Protection
- 28 Interpreting certification and approval codes for hazardous area electrical equipment
- 30 On-Going Maintenance of Static Control Procedures and Equipment
- 31 Safety-Checklist

Effective Control of Static Electricity through Grounding and Bonding

Static electricity, or the build up of electrostatic charge, is present all around us. In everyday life, a static spark is seen as a nuisance; in a combustible atmosphere, its effect can be catastrophic. Many plant fires and personnel injuries can be directly linked to an electrostatic spark igniting a vapour, gas or dust atmosphere. There are, however, various protective measures that can be adopted across industry to control this ever-present threat to people, plant and processes.

When implementing safety measures in potentially explosive atmospheres, there are many issues to consider. Eliminating potential ignition sources is the best starting point, both in terms of good engineering design and general operating procedures. However, in any type of combustible atmosphere there may be hidden dangers present, in the form of “isolated conductors”. These are conductive objects which are either inherently or accidentally insulated from ground, preventing any static electricity generated from safely dissipating, thus resulting in accumulation of charge on the object. These isolated conductors include metal flanges, fittings or valves in pipework systems; portable drums, containers or vessels; road tankers, rail cars and even people! Isolated conductors are probably the most likely source of static ignition incidents in industry.

To understand the extent of the danger and how it may be controlled, the fundamentals of static electricity, and how it is manifested, must be considered. In any industrial process where there is movement, the coming together and separation of materials will generate static. This could be liquid flowing through a pipe, powder dropping down a chute, a mixing process, or a person walking across a floor. While the potential differences (voltages) induced on objects can be very high, the extent of the streaming current is usually very low, typically no greater than 0.1 mA. If the object or piece of plant is in good enough contact with ground, this charge will be dissipated as it is generated. However, if the object is insulated from ground, the charge will start to accumulate, leading to an increase in voltage.

Tyres on vehicles, paints, coatings, gaskets, seals and other non-conductive materials can all be sufficiently insulating to prevent safe static dissipation. Static charge can quickly build up to a very high potential, with voltages ranging from 5 kV to in excess of 30kV. Depending on the capacitance of the object, this may result in significant levels of energy available for discharge, well above the minimum ignition energy (MIE) of the surrounding flammable atmosphere.

The voltage of objects rise quickly when the resistance of the path from the object being charged, to ground, impedes the dissipation of charges. When another object that is at ground potential (or lower potential), comes in to close proximity to the charged object an electrical field is immediately set up between both objects. Spark discharges occur when the electric field strength exceeds the breakdown voltage of the atmosphere between the two bodies. The average breakdown voltage of air is approximately 3 kV per millimetre. However, owing to many variables including charging mechanisms, charge generation rates, the breakdown strength of the air, gas or vapour mixture, the resistance to ground of objects and even the geometry of objects, it cannot be assumed that lower potentials will not discharge incendive electrostatic sparks.

The potential energy of static spark discharge can be calculated from the formula:

$$W = \frac{1}{2} CV^2$$

where:

W = The potential energy of a spark discharge (mJ).

C = The capacitance of object subjected to charge accumulation.

V = The voltage of object, caused by charge accumulation.

Typical MIEs vary according to whether the flammable atmosphere comprises vapour, dust or gas, but many commonly used solvents have MIEs of well below 1 millijoule (see Tables A & B). If the isolated conductor comes into proximity with another object at a lower potential, much of this energy could be released in the form of an incendive electrostatic spark. Of course, in order for an ignition of the combustible atmosphere to occur, there would also need to be a suitable concentration of fuel (vapour, dust or gas) in the air; but for the purposes of safe plant design, the very fact that there is an identified combustible atmosphere should suggest that ignition is possible or likely. The problems associated with isolated conductors can be remedied by effective grounding (also known as “earthing”) and bonding.

Table A: Potential energy on typical plant items

Object	Capacitance (pF)	Stored energy at 10kV (mJ)	Stored energy at 30kV (mJ)
Road Tanker	5000	250	2250
Person	200	10	90
Steel Bucket	20	1	9
100mm Flange	10	0.5	4.5

Table B: Minimum ignition energy of vapours & powders

Liquid vapour	MIE (mJ)	Powder cloud	MIE (mJ)
Propanol	0.65	Wheat Flour	50
Ethyl Acetate	0.46	Sugar	30
Methane	0.28	Aluminium	10
Hexane	0.24	Epoxy Resin	9
Methanol	0.14	Zirconium	5
Carbon Disulphide	0.01	Some Pharmaceutical Intermediates	1

data source: UK IChemE

“Grounding” may be defined as linking the conductive object to a known “grounding point” via a mechanically strong and electrically conducting cable, thereby ensuring the object is at 0V, or otherwise known as ground potential. “Bonding” (or equipotential bonding) may be described as linking together adjacent conductive objects so as to equalise the potential difference between them. At some point these linked items should be grounded, ensuring that all conductive objects are at ground potential. In the case of fixed installations such as pipework, storage tanks etc., this is relatively simple to implement. However, it is more difficult in the case of mobile / portable objects such as tank trucks, vacuum trucks, drums and IBC's (intermediate bulk containers). In these instances, purpose-designed temporary grounding and bonding devices should be used, with strict procedures in place, to ensure they are always connected prior to starting the process. This will prevent any static charge accumulation.

In the case of people, static dissipative (S.D.) footwear and gloves may be worn to ensure that the person is continually “grounded”. Testing devices are available to ensure that footwear conforms to the relevant standard (eg. EN ISO 20345, the Cenelec 50404 level in Europe or ASTM F2413-05 in the U.S.). When a working area is designed, it is important to ensure that the floor has a suitable level of conductivity, as static dissipative footwear will be rendered ineffective if the wearer is walking on an insulating floor or floor covering. If the combustible atmosphere has a very low MIE, static dissipative clothing may also be required.

Even when the appropriate static safety equipment has been specified, there are some further concerns that must be addressed by all those responsible for operations within potentially explosive atmospheres. In operational terms, attaching a grounding clamp to a plant item is always a “physical” action. Even if the operators diligently carry out their

duties as detailed in company safety procedures, they can never be sure that the clamp has made a low enough resistance connection with the conductive object to enable any static generated to be safely dissipated to ground.

The fact remains that many conductive objects that are capable of accumulating high levels of static charge also have insulating layers on their surfaces that may prevent the necessary low resistance contact. This may be caused by the paint or coating on drums, tank trucks, vacuum trucks and other mobile plant, or may be the result of product build-up caused by normal working conditions (for instance where insulating liquids, powders and other materials are part of the process). Many grounding and bonding clamps show very high resistance readings when clamped onto conductive objects with insulating surfaces. Worse still, if a company tries to reduce costs by using standard welding clamps or lightweight alligator clips for static grounding in place of purpose designed and approved clamps, these devices have an even higher failure rate.

To solve this problem, Intrinsically Safe, self-testing grounding clamps may be specified. From an operator's point of view, these devices are used in exactly the same way as conventional grounding clamps. Where they differ is in the way that they reassure the operator that the clamp has not only been physically attached, but is also performing its intended function of safely dissipating any static electricity that is generated. These clamps employ active electronic monitoring circuits that are powered from an internal low energy battery or a certified, externally mounted, line power supply and I.S. interface. The circuit is only completed when the clamp achieves a low resistance contact onto the object to be grounded, and the operator receives visual confirmation of this via an indicator (usually a flashing LED). The self-testing grounding clamp also monitors cable condition back to the designated grounding point, and will also fail to register a permissive signal if the cable has worked loose or is broken.

To move to an even higher level of security, ground monitoring systems may also be used that not only give visual verification to the operator, but also provide interlock switching contacts that may be linked to process pumps, valves, alarms or control systems. This means that the process cannot be started until the conductive object has been safely grounded and if at any time during the operation the condition changes (due to a clamp being accidentally removed, etc), the system automatically switches to non-permissive and shuts down the process.

These systems are generally powered by a line fed power supply, and employ approved Intrinsically Safe circuits to limit the monitoring energy to safe levels. Systems may also be fitted to tank trucks or vacuum trucks and can be powered by the vehicle battery. Static ground monitoring and Interlock systems are typically used in ultra safety-critical applications such as loading / unloading tank trucks, vacuum trucks, IBCs, mixing processes, fluid bed drying operations and wherever there is a high likelihood of static charge accumulation in very low minimum ignition energy (MIE) combustible atmospheres.

Static ground monitoring clamps and grounding systems with equipment interlock capability tend to have an important beneficial effect on the operators using them. As their use builds an “additional” check into the operation, they help reinforce the static safety procedures of the company. In short the operator is more likely to observe the correct procedures as he or she is kept aware of the need to control static electricity properly on a daily basis.

In all situations, it is important to make regular, periodic tests of the control measures used, checking clamp and cable condition and the all-important connection back to the grounding point (bus bar). Resistance testers or multi-meters may be used to perform this function but, of course, these will need to be approved Intrinsically Safe instruments if working when a potentially combustible atmosphere may be present. Recording of test results is a positive way of ensuring that standards are maintained. The frequency of testing will depend on the nature of the operation and the type of control measures in place: generally, non-monitored devices will need to be tested more frequently than self-testing clamps or interlocked equipment.

In addition to these engineered static safety controls, due consideration should also be given to all plant and packaging materials used within the hazardous area. Today, specialised “non-metallic static dissipative” materials are increasingly being used for making drums, flexible containers, linings, and hoses, in applications not suited to traditional materials such as steel. Such materials are safe to use in combustible atmospheres, provided that they are treated in the same way as conductive items and appropriately grounded during static-generating operations. It is important to note that insulating plastics, such as those used in certain IBCs and bags, may pose a serious static-ignition risk. These materials cannot be safely grounded and it is not recommended to use them where a combustible atmosphere is likely to be present.

It should also be noted that charge can build up on the actual materials being processed (liquids, powders, gases), so it is necessary to make sure that these are in sufficient contact with grounded, conductive piping, vessels and plant, thus providing a safe discharge path. Conductive materials in good contact with a ground path will not retain significant levels of charge. However, as many of these materials are highly resistive, it is imperative to ensure that any conductive equipment (e.g. pipes, drums, containers, tank trucks, vacuum trucks) with which the charged material comes into contact are grounded or bonded to grounded objects.

In conclusion, the dangers of static electricity in hazardous areas demand a “holistic” approach to plant, process and personnel safety, as any control measures are only as good as the weakest link in the chain. As the speed and scale of modern manufacturing techniques increase, and the range of materials used and processed grows, this basic approach to safety will be even more important.

Static Grounding Safety Summary

1. Always use correctly approved and specified, purpose designed grounding and bonding clamps, cables and devices.
2. Check all grounding application characteristics and consider positive verification and interlock systems for places where further safety and security is required.
3. Ensure all operators working in hazardous areas understand the risk of static ignition and follow correct company safety procedures.
4. Ensure that a proper maintenance programme is followed for grounding and bonding measures.

Note: this guidance assumes that qualified personnel have carried out appropriate risk assessments and hazardous location zoning work. For example within Europe, this would form part of compliance with the ATEX 137 Directive (99/92/EC). Please note that any advice offered is intended to make a contribution towards effective static control practice and it is drawn from the publications mentioned overleaf and other related materials. However it should not be regarded as an exhaustive list of solutions for particular problems, and it is always the responsibility of the operating company to verify the efficiency and effectiveness of any static control measures employed.

International Standards for Controlling the Hazards of Static Electricity in Potentially Combustible Atmospheres

Which standards apply?

Static electricity is a very real and ever present threat within the hazardous process industries. For this reason, many agencies and industrial associations publish standards that help companies identify processes where the risk of incendive electrostatic discharges are likely to be present.

There are five primary standards that Newson Gale adheres to in order to incorporate “benchmark” recommendations into static grounding and bonding solutions. The standards listed below are published by the National Fire Protection Association, Cenelec, the American Petroleum Institute, the British Standards Institute and the International Electrotechnical Commission.

NFPA 77: Recommended Practice on Static Electricity (2007).

Cenelec CLC/TR 50404: Code of Practice for the Avoidance of Hazards due to Static Electricity (2003).

API RP 2003: Protection against Ignitions Arising out of Static, Lightning and Stray Currents (2008).

API RP 2219: Safe Operation of Vacuum Trucks in Petroleum Service (2005).

BS 5958: Code of Practice for Control of Undesirable Static Electricity (1991).

IEC 61340-4-4: Electrostatic classification of Flexible Intermediate Bulk Containers (2012).

These standards recommend solutions to static electricity hazards that focus on controlling the generation and accumulation of electrostatic charges. The generation of static electricity can be controlled through material processing velocities, upstream location of charge generating equipment (e.g. filters) and the use of “anti-static” additives. Many of these solutions may, however, not be implementable due to productivity, product formulation or capital investment constraints.

The most effective way of controlling static electricity is to prevent its accumulation on all potentially isolated plant equipment, including tank trucks, vacuum trucks, people, portable containers like drums, IBCs/totes and FIBC (Big Bags), fluid bed dryers, hoppers any other equipment at similar risk. The most effective way of preventing charge accumulation is to ground and bond the equipment.

In order to provide some benchmarks for grounding equipment that is capable of discharging static sparks, the standards recommend how the equipment should be

grounded and what levels of resistance should be present on protective static grounding and bonding circuits.

The Key Benchmark is 10 ohms.

Each of the five standards state that 10 ohms should be the maximum level of electrical resistance between the object to be grounded and the site’s verified earth ground as greater resistance in continuous metal paths would indicate loose connections, coatings / product build up and problems like corrosion, which could impede the flow of static electricity. This value of resistance includes the connection resistance of the grounding clamp to object to be grounded, the resistance of the cable, and the connection resistance to the site’s designated earth grounding point.

Metal grounding circuits can be classed as consisting of conductive metal equipment that requires static grounding protection (e.g. drums and tank trucks), grounding clamps with sharpened metal teeth and single pole cable or the circuits of two pole ground monitoring systems.

For non-metallic grounding circuits, e.g. equipment that is not made of metal, like Type “C” FIBC or Static Dissipative Plastic (SDP) containers, CLC/TR: 50404 and IEC 61340-4-4 specify maximum values of resistance to a verified earth ground.

	Metal Circuits	Type C FIBC & SDP containers
NFPA 77	10 ohms	must be grounded
CLC/TR: 50404	10 ohms	1 x 10 ⁸ ohms
API 2003	10 ohms	no reference
API 2219	10 ohms	no reference
BS 5958	10 ohms	must be earthed
IEC 61340-4-4	N / A	1 x 10 ⁷ ohms

When an audit of a process or procedure has identified an electrostatic ignition hazard, it is important to specify grounding and bonding solutions that can demonstrate compliance with the standards for controlling the hazards of static electricity in the industrial workplace, ensuring personnel and company assets are protected from this ever-present and hazardous ignition source.

Grounding and Bonding Equipment Solutions

Newson Gale static grounding and bonding solutions are divided into three product ranges which enable customers to specify static control solutions based on the type of process being carried out, the scale of charge accumulation and the potential consequences of an incendive electrostatic discharge.

The Earth-Rite® and Bond-Rite® range utilise Intrinsically Safe electronics that continuously monitor the condition of the grounding circuit, (ground loop) from the equipment requiring static grounding protection back to the site designated earth ground.

In addition, the Earth-Rite® range of equipment contains output contacts that can be utilised to permit the movement of product only when the equipment at risk of charge accumulation is securely grounded. Strobe lights or sounder alarms can also be specified.

The integrity of the ground loop is verified by the grounding equipment which monitors to a resistance of 10 ohms or less. A higher resistance value will indicate that the equipment is not securely grounded. The operator in control of the process can verify when the equipment is grounded by means of an

indicator located on the grounding equipment.

Where equipment that is manufactured from “static dissipative” materials is used, e.g. Type “C” FIBCs, values of resistance based on recommendations from the standards listed on Page 6 will apply.

The Cen-Stat™ range of grounding clamps undergo compliance testing to Factory Mutual specifications to ensure their design and function can perform secure and reliable grounding of equipment. In addition the clamps are ATEX certified for use in all hazardous areas.

All grounding cables are protected by a Newson Gale formulated protective coating that incorporates high resistance to chemical, UV and mechanical attack. The cable is static dissipative which ensures no charge can build up on the cable when it is being used by process operators.

The following table summarises the features and user benefits of the Newson Gale range of static grounding and bonding solutions. Examples of these solutions are illustrated on the Application diagrams located on pages 9 to 25 of this Handbook.

Features	User Benefits	Earth-Rite®	Bond-Rite®	Cen-Stat™
System Control Outputs	If the system detects that the ground connection has been compromised the outputs can control electromechanical equipment to prevent static charge build up or alert personnel with annunciators or hazard strobe lights.	✓		
Visual Verification of a positive ground connection	Provides operators with visual indication of a positive static dissipative ground connection.	✓	✓	
Continuous Ground Loop Monitoring	Ensures the static dissipative circuit is continuously monitored throughout the application process.	✓	✓	
ATEX / FM Approved Grounding Clamps	Provides low resistance electrical connection using tungsten carbide tips to penetrate hardened deposits, coatings, rust and dirt.	✓	✓	✓
Cen-Stat™ Coated Cable & Reels	Cen-Stat™ cable hi-visibility static dissipative protective coatings providing high mechanical durability and chemical resistance.	✓	✓	✓

Earth-Rite®, Bond-Rite® and Cen-Stat™ are registered Trademarks of Newson Gale®

Application Drawings

The following pages contain “Application Drawings” which illustrate how to specify static grounding solutions for specific processes while ensuring the safety level provided by the solution satisfies the scale of the potential fire or explosion hazard.

Each Application Drawing illustrates scenarios of how, and where, the static grounding equipment can be installed and used in order to provide static grounding protection for the equipment.

Recommendations from the standards listed on Page 6 are included to support the methods of grounding that are illustrated on each application drawing.

With the exception of systems that verify their own earth ground connections, most of the static grounding applications illustrated require the availability of a dedicated static grounding point with a verified connection to True earth.

Designated static grounding points can be assigned to parts of the building structure, bus-bar systems or grounded electrical equipment that form part of this grounding network to verified earth ground.

On the Application Drawings these points are indicated by the internationally recognised earth / ground symbol \perp .

The Last Hurdle - The Resistance to True Earth

One of the most important functions of the measures taken to protect against the accumulation of static electricity, is not only verifying a low resistance connection to the equipment at risk of charge accumulation, but also verifying that the static grounding equipment itself, is connected to “True earth”.

True earth is recognised as the general mass of the Earth that can safely receive and distribute the charges that result from electrical fault currents (stray currents), lightning stroke currents and static electricity currents. We cannot be sure that the equipment is safely grounded, without verifying that the static grounding system is bonded to a point that is designated as being connected to True earth.

The resistance to True earth is represented by ‘shells’ of soil resistance surrounding an electrode that is performing the intended function of providing electrical fault protection, lightning protection and electrostatic grounding protection. The resistance between the ground electrode and True earth is the last hurdle to safely transferring static charges to ground.

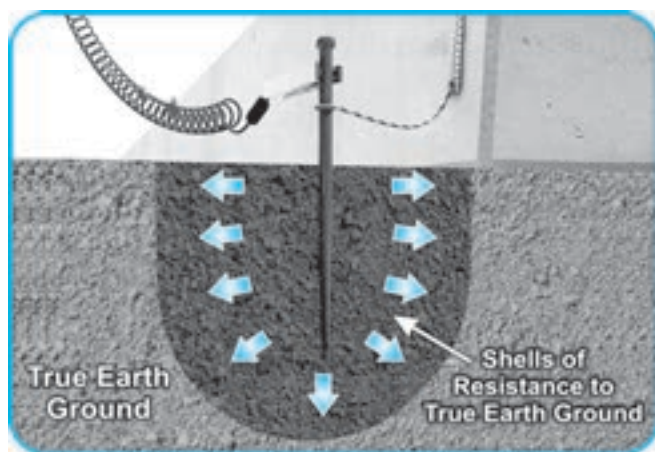

Permanent lightning and stray current protection systems are usually designed and installed by engineers specialising in electrical grounding and the required values of resistance will be determined by the function of the installation. All sites with classified hazardous areas should have electrical fault and lightning

protection systems that have been tested by engineers in accordance with local codes and regulations. These are normally referred to as “designated” earth grounding points. These points can also be used to ground plant equipment and vehicles at risk of static charge accumulation. These “primary” grounding points should be regularly tested to ensure they will not only function as reliable paths to earth for stray currents and lightning currents, but also protect against the accumulation of static electricity.

When looking at static electricity as distinct and separate from the hazards of lightning and stray currents, much higher values of resistance to True earth are permitted. This is because the magnitude of static charging currents are low when compared with lightning and stray currents, even though the hazardous voltages associated with static electricity are very high (see page 3 and 4).

This is why static ground verification systems like the Earth-Rite[®] MGV and Earth-Rite[®] RTR are capable of verifying that the ultimate resistance to earth of both primary (designated earth grounding points) and secondary earth grounding points do not exceed 1000 ohms, a level well below the maximum recommended for safe static dissipation.

Secondary earth grounding points are objects like pipes running beneath the ground, beams of building structures, storage tanks and temporary grounding rods. These are structures that will not be tested to verify their suitability for fault current and lightning protection, however, because of their permanent contact below the surface of the ground, are not likely to have resistance values to True earth that would impede the safe transfer of static electricity.

However, the resistance to True earth will be influenced by the resistivity of the soil surrounding these objects. Seasonal changes in moisture content and soil temperatures can have a detrimental effect on resistance values.

If the validity of primary earth grounding points is not fully known, or secondary earth grounding points must be used, they should be tested by systems with Static Ground Verification technology prior to their use. A verified resistance of 1000 ohms, or less, will safely allow the rapid transfer of static charging currents to True earth, ensuring equipment at risk of charge accumulation is protected from incendive static spark discharges.

Grounding a Tank Truck

Using a tank truck ground monitoring / interlock system

If additional information on the solution(s) illustrated is required contact Newson Gale or your local Newson Gale supplier and quote the Issue number of the Handbook and the page number on which the product is illustrated. Both numbers are located at the bottom of each Application page.



© Newson Gale Ltd.



Earth-Rite RTR with Road Tanker Truck Recognition with 10 mtr. (32 ft.) spiral cable.
RTRMEA1A3A - IECEx/ATEX
RTRMUA1A3A - North America



Earth-Rite RTR with Road Tanker Truck Recognition with 15 mtr. (50 ft.) reel option.
RTRMEA4A7A - IECEx/ATEX
RTRMUA4A7A - North America

Owing to the high electrostatic ignition risk associated with filling or unloading an ungrounded tank truck, sites follow the Genelec Code of practice CLC/TR 50404, NFPA 77 and API RP 2003 recommendations of providing an interlocked ground monitoring system to prevent product transfer if the grounding cable is not connected.

A grounding system that combines Road Tanker Truck Recognition technology, that ensures the grounding clamp is correctly attached to the body of the tank truck at risk of charge accumulation or other metal objects (e.g. not to parts of the chassis that are isolated from the tank), with Static Ground Verification technology, to verify it is connected to a static earth ground, will automatically ensure the system is operating safely as well as preventing dangerous misuse. Such a system will ensure that the following procedure is followed.

CLC/TR 50404 states:

“An earthing cable should be connected to the tanker before any operation (eg. opening man lids, connecting pipes) is carried out. It is recommended that interlocks should be provided to prevent loading when the earthing cable is not connected”. (5.4.4.1.2).

Grounding Rail Cars

Using the Earth-Rite PLUS

If additional information on the solution(s) illustrated is required contact Newson Gale or your local Newson Gale supplier and quote the Issue number of the Handbook and the page number on which the product is illustrated. Both numbers are located at the bottom of each Application page.



Earth-Rite PLUS with
10 mtr. (32 ft.) spiral cable.
PLUSMEA1A3 - IECEX/ATEX
PLUSMUA1A3 - North America



Bond-Rite REMOTE with
10 mtr. (32 ft.) spiral cable.
BRRPEB2A3 - IECEX/ATEX
BRRPUB2A3 - North America

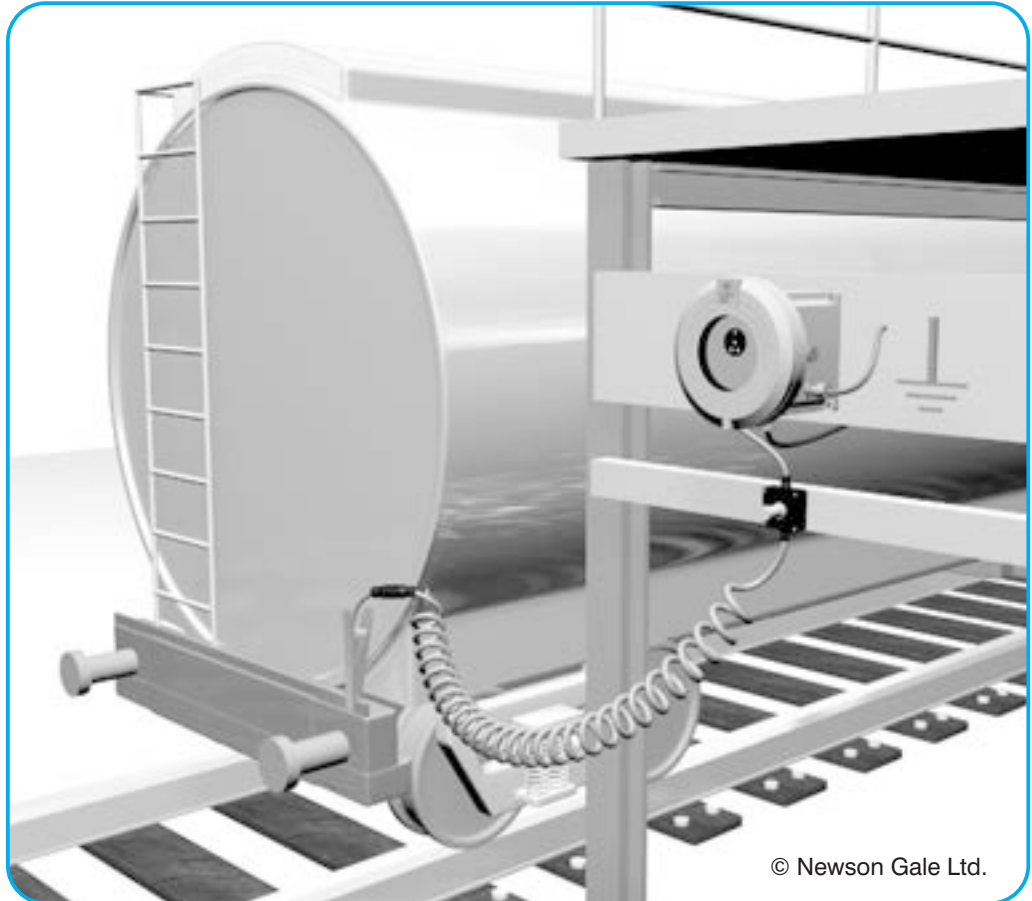

© Newson Gale Ltd.

Bulk Loading or unloading Rail Cars with liquids or powdered / loose solid materials can generate large electrostatic charges, and this poses a significant risk in a potentially explosive atmosphere. Although the Rail Car is in contact with (grounded) tracks, many tank cars are equipped with non-conductive bearings and wear pads located between the car itself and the wheel assemblies. This may lead to an unsafe condition where an ungrounded Rail Car accumulates a high static charge. Ground Monitoring/Verification systems may be used to provide an interlock with the filling systems to prevent product transfer unless the Rail Car is grounded.

The Earth-Rite PLUS provides indication of a proper ground, as well as relay contacts to control the transfer process, while the Bond-Rite REMOTE is useful for visual verification purposes and is available in line-feed or battery operated versions, making it easy to install and operate for remote locations.

NFPA 77 states:

“bonding of the tank car body to the fill system piping is necessary to protect against charge accumulation. In addition, because of the possibility of stray currents, loading lines should be bonded to the rails.” (8.8.2).

Grounding Service Vehicles / Vacuum Trucks

Using a Mobile Static Ground Verification system

If additional information on the solution(s) illustrated is required contact Newson Gale or your local Newson Gale supplier and quote the Issue number of the Handbook and the page number on which the product is illustrated. Both numbers are located at the bottom of each Application page.



© Newson Gale Ltd.



Earth-Rite MGV
(Mobile Ground Verification system).
MGVP1ED7A4-KC - IECEx/ATEX
MGVP1UD7A4-KB - North America



Earth-Rite MGV Grounding Kit.
SWGKP1

When working in hazardous locations, specialised trucks and service vehicles are commonly equipped with bonding reels that are used to bond the truck to a grounding point. Typical grounding points include underground piping, storage tanks, grounded electrical equipment or a network of ground rods if man-made structures are not present at the location.

However, bonding reels of this nature have severe limitations in that they cannot verify that the point to which they are connected can function as a True Earth Ground that is capable of dissipating static charges from the truck.

In addition bonding reels are not capable of monitoring their connections to grounding points. If the connection is broken, the drivers have no way of having their attention drawn to this potential hazard.

The Earth-Rite MGV system utilises Static Ground Verification technology to verify that the grounding point the truck is connected to is, itself, connected to a True Earth Ground. The MGV also monitors the quality of the connection to the grounding point for the duration of the transfer process.

For general recommendations regarding vacuum trucks refer to **API 2219 "Safe Operation of Vacuum Trucks in Petroleum Service"** which states:

"before starting transfer operations, vacuum trucks should be grounded directly to earth or bonded to another object that is inherently grounded such as a large storage tank or underground piping" (5.4.2). "This system should provide an electrical contact resistance of less than 10 ohms between the truck and a grounded structure" (5.4).

Grounding of Mixing / Blending / Filling Machines

Using Earth-Rite TELLUS II

If additional information on the solution(s) illustrated is required contact Newson Gale or your local Newson Gale supplier and quote the Issue number of the Handbook and the page number on which the product is illustrated. Both numbers are located at the bottom of each Application page.



Earth-Rite TELLUS II
(with Power Supply Unit).
TEL2E1B - IECEX/ATEX
TEL2U1B - North America



Close up of Earth-Rite TELLUS II
Intrinsically Safe Indicator Station.



© Newson Gale Ltd.

Plant equipment used in processes like chemical blending, paint & coatings mixing and drum filling are susceptible to the risk of static ignitions if charges generated by the process do not have a positive static dissipative path to ground. Such equipment may have painted or contaminated surfaces, and additional build up of products (resins, coatings, powders, etc.) can make effective grounding and bonding difficult to achieve with regular mechanical clamps.

The combination of a flashing LED and system safety interlocks can provide an optimum solution to situations where the risk of damage to personnel, product and plant assets needs to be managed.

The flashing LED provides the operator with information indicating the grounding system has established a positive static dissipative connection with the equipment (≤ 10 Ohms). For rapid loading of drums the safety interlock can quickly shutdown transfers should operators fail to detect the loss of a positive ground connection. The lightweight and compact intrinsically safe indicator station is easy to mount on mixing and filling equipment close to the point of use.

BS 5958 states that when mixing and blending:

"All metallic parts of the equipment should be connected together and earthed so that the resistance to earth at all points is less than 10 ohms." (10.2.1).

Grounding Flexible and Rigid IBCs

Using appropriate ground monitoring / interlock systems

If additional information on the solution(s) illustrated is required contact Newson Gale or your local Newson Gale supplier and quote the Issue number of the Handbook and the page number on which the product is illustrated. Both numbers are located at the bottom of each Application page.

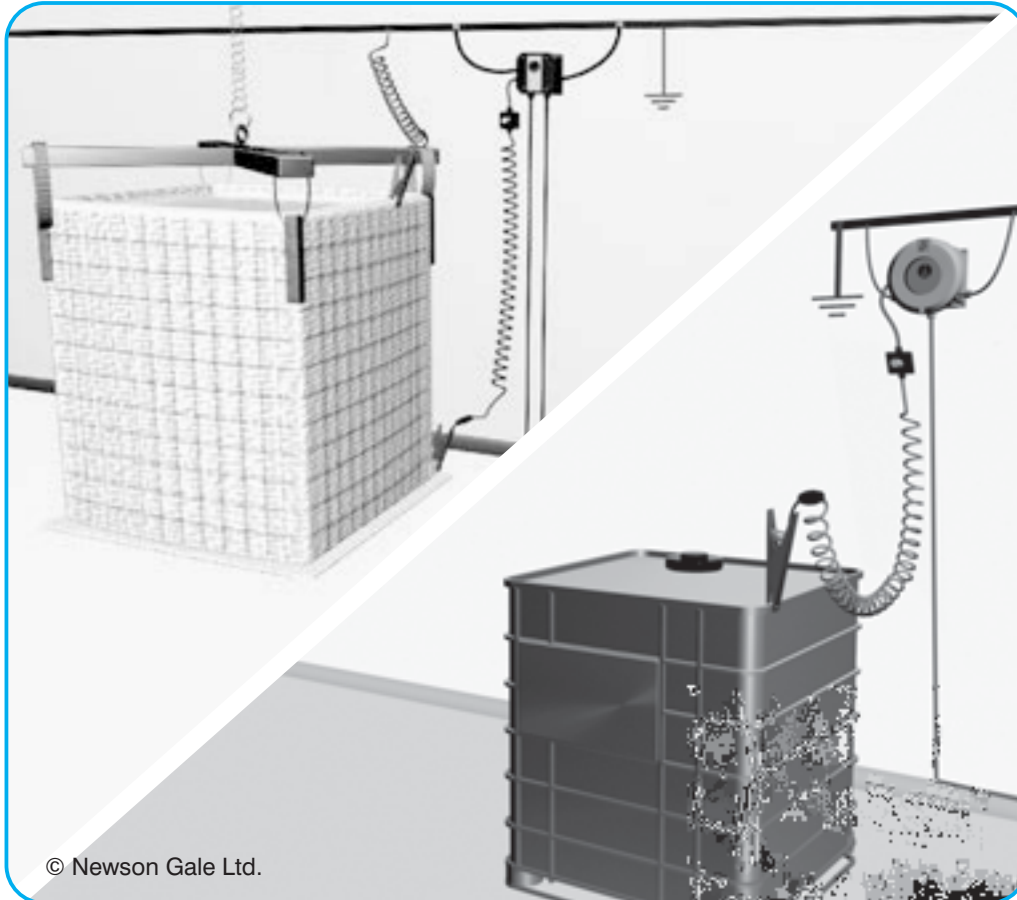

Earth-Rite FIBC
Intrinsically Safe Monitoring Unit.
FIBC8P1EA1A1 - IECEX/ATEX
FIBC8P1UA1A1 - North America



Earth-Rite PLUS
PLUSMEA1A2 - IECEX/ATEX
PLUSMUA1A2 - North America

When filling or emptying either rigid containers manufactured from static dissipative plastic (SDP) or Type C flexible intermediate bulk containers, ground monitoring systems should be used to prevent product transfer unless the grounding system is connected to the container.

For static dissipative materials, a system with a monitoring range appropriate to the type of container should be selected. Containers made of SDP and Type C FIBCs should be monitored at a resistance $\leq 1 \times 10^8$ ohms (CLC/TR: 50404). For conductive / metal materials, a resistance of ≤ 10 ohms should be the monitored resistance to the dedicated earth / ground point.

CLC/TR 50404 states:

"The conductive fabric and the conductive threads (including the handles) shall have a resistance to the earthing point on the FIBC of less than 1×10^8 ohms... In order to prevent spark discharges, the FIBC Type C shall be properly earthed whenever being filled or emptied." (7.2.6.8.3).

*For users of bags conforming to IEC 61340-4-4 a system that monitors FIBC at $\leq 1 \times 10^7$ ohms is available.

Grounding Interconnected Plant Items, Pipes and Ducting

Using a multi-channel ground monitoring / interlock system

If additional information on the solution(s) illustrated is required contact Newson Gale or your local Newson Gale supplier and quote the Issue number of the Handbook and the page number on which the product is illustrated. Both numbers are located at the bottom of each Application page.



Earth-Rite MULTIPPOINT
EMUM50 with up to 8 channels.



Quick Release Plug
& Socket Connector.
VESF30 - Plug
VESF31 - Socket

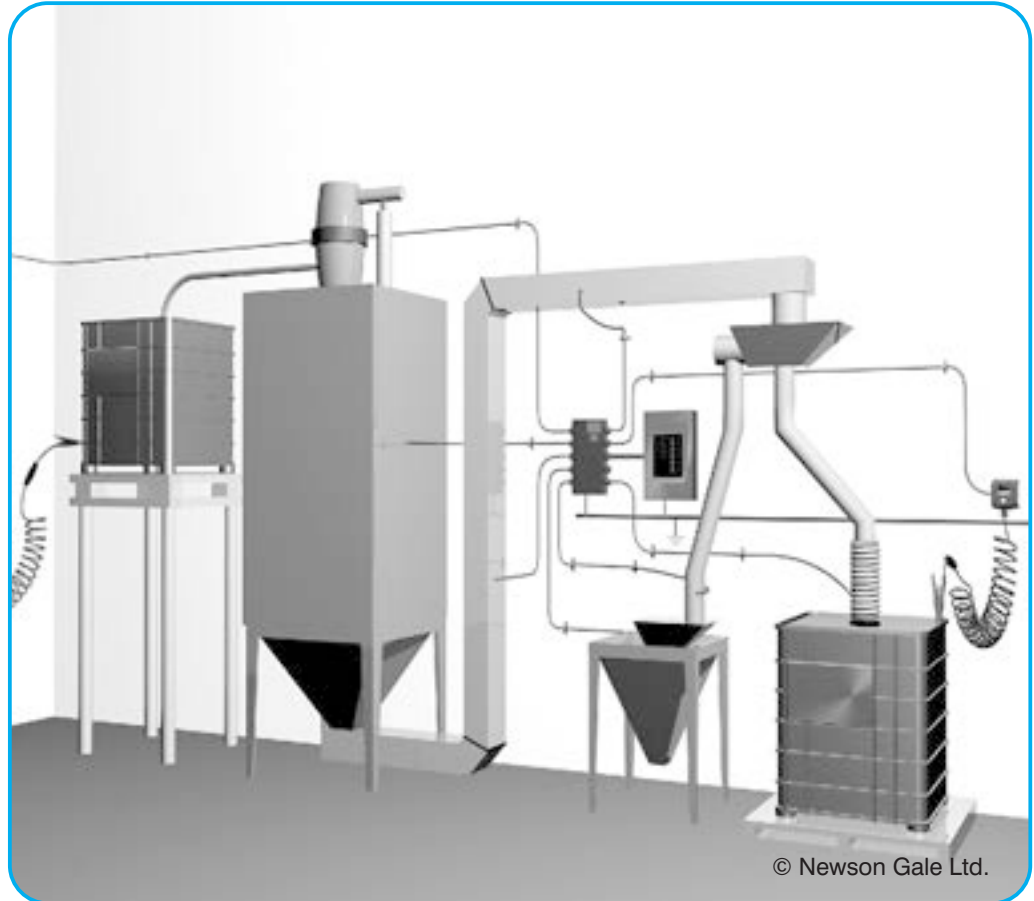

Ground monitoring of individual plant sections is common, as interconnected process items must be kept at the same electrical potential and bonded to a designated ground connection. Ungrounded transfer pipes and ducting are prone to static charge accumulation and are often ground monitored, particularly when they are disassembled regularly for cleaning and ongoing maintenance.

It is very important to ensure that the monitoring equipment selected will not allow the sum of circulating currents from the various monitoring channels to exceed permitted levels for Intrinsic Safety.

NFPA 77 states:

“Resistance in continuous ground paths will typically be less than 10 ohms. Greater resistance usually indicates the metal path is not continuous, usually because of loose connections or corrosion” . (7.4.1.3.1).

Grounding a Fluid Bed Drier and its Components

Using a multi-channel ground monitoring / interlock system

If additional information on the solution(s) illustrated is required contact Newson Gale or your local Newson Gale supplier and quote the Issue number of the Handbook and the page number on which the product is illustrated. Both numbers are located at the bottom of each Application page.

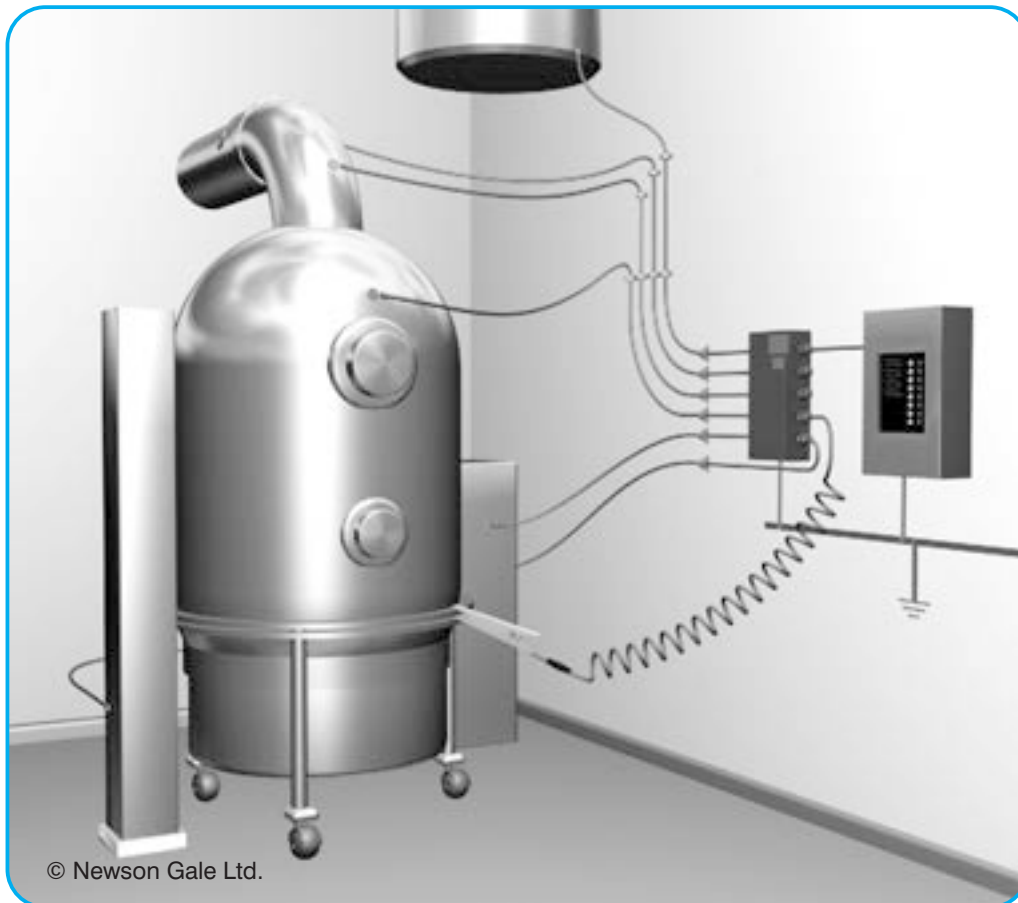

Earth-Rite MULTIPoint.
EMUM50 with up to 8 channels.



Stainless Steel Two Pole Clamp
& 5 mtr. (16 ft.) retractable cable.
IPX90/2B05Q.

There are many items of plant that have interconnected metallic parts. Large scale driers, such as fluid bed or spray driers, as used in the pharmaceutical or food processing industries, have a product bowl, filters or ducting that are often disconnected in everyday operation.

These parts may have insulating gaskets etc between them and could be isolated from ground if they are not properly reconnected using their bonding straps. As it is time-consuming to test these connections after each reassembly, many sites choose to actively monitor the ground condition of such separate sections.

BS 5958 states:

"All metallic parts...should be connected to each other and to earth, so that the resistance to earth at all points is less than 10 ohms". (16.2.1).

Grounding Rotating Vessel and Fixed Container

Using dedicated ground monitoring / interlock modules

If additional information on the solution(s) illustrated is required contact Newson Gale or your local Newson Gale supplier and quote the Issue number of the Handbook and the page number on which the product is illustrated. Both numbers are located at the bottom of each Application page.



Earth-Rite OMEGA module
VESF70



4 Earth-Rite OMEGA modules DIN
rail mounted

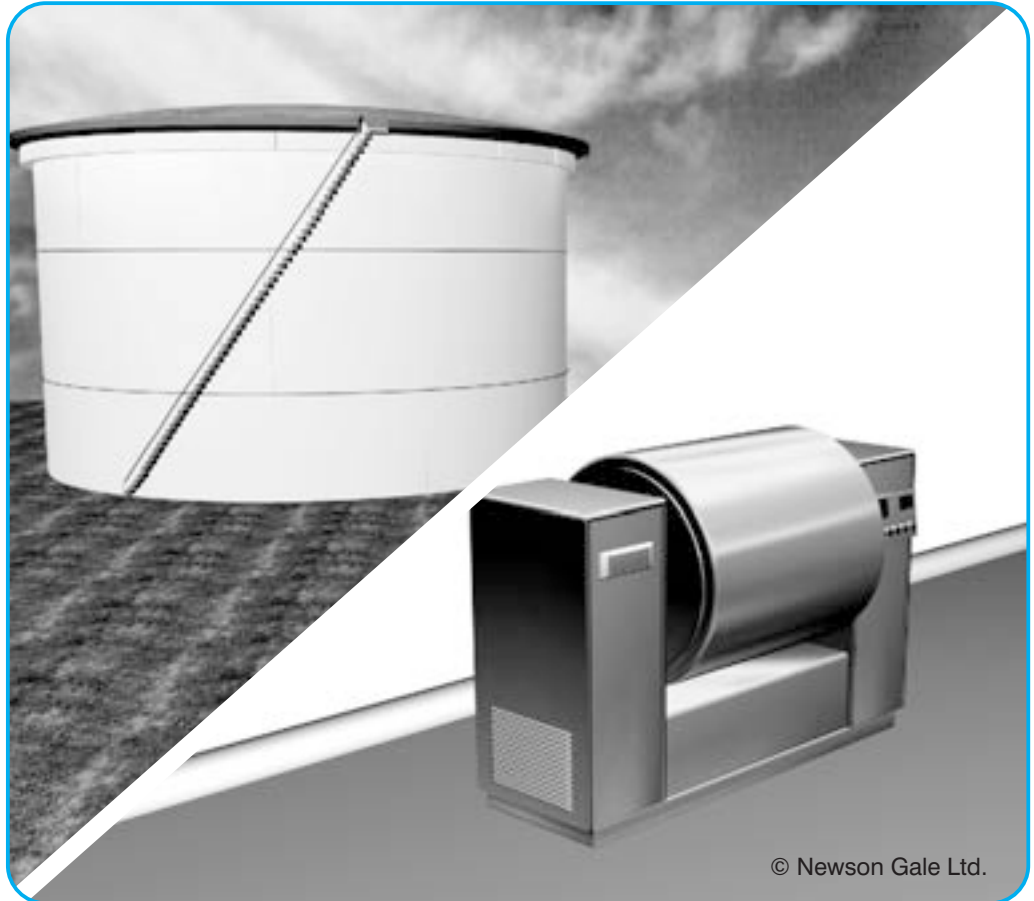

© Newson Gale Ltd.

Ensuring that a rotating drum or impeller is correctly grounded may be difficult as it is not always possible to rely on the connection made from its shaft to the body of the machine, owing to the design of bearings, etc. A popular method of guaranteeing ground continuity is to use a ground monitoring module to test the ground connection to the drum or impeller via a pair of carbon brushes or a slip ring, acting on the shaft.

Such modules may also be used to test the ground connection to key items of fixed plants, such as large storage vessels for flammable liquids.

NFPA 77, when discussing the static dissipation path through bearings (in this case, railcar wheel assemblies) **states:**

“resistance to ground... might not be low enough to prevent the accumulation of static electric charge” (8.8.2).

Grounding Drums and Containers

Using self-testing clamps and cables

If additional information on the solution(s) illustrated is required contact Newson Gale or your local Newson Gale supplier and quote the Issue number of the Handbook and the page number on which the product is illustrated. Both numbers are located at the bottom of each Application page.



Bond-Rite Clamp & 5 mtr.
(16 ft.) cable.
BRC05



Replacement Bond-Rite Clamp
with In-Line Quick Connector.
VESC50

For complete reassurance that a suitable low resistance connection has been achieved, self-testing clamps with a built-in LED indicator are recommended for safety-critical operations, such as manual product transfers between drums and containers. Being operated by an internal battery, they are ideal where simple installation is desirable and an interlock is not required.

By confirming the reliability and condition of connections via the pulsing LED, self-testing clamps enable the user to conform with **CLC/TR 50404** which states:

“What is most important.....is that all connections are reliable.....and not subject to deterioration”. (11.2.2)

NFPA 77 states:

“In bonding and grounding installations that are prone to corrosion, movement, or insulating surface coatings, self-testing bonding clamps and systems can be used to continuously test the resistance to ground and verify acceptable results.” (6.8.4)

Grounding Drums in a Drum Store or Processing Room

Using mains powered self-testing clamps and cables

If additional information on the solution(s) illustrated is required contact Newson Gale or your local Newson Gale supplier and quote the Issue number of the Handbook and the page number on which the product is illustrated. Both numbers are located at the bottom of each Application page.



Bond-Rite REMOTE (EP) with
Stainless Steel Heavy Duty Clamp.
BRRPEP2A1 - IECEX/ATEX
BRRPUP2A1 - North America



Bond-Rite REMOTE (EP).
ER/UPS/AC - Power Supply

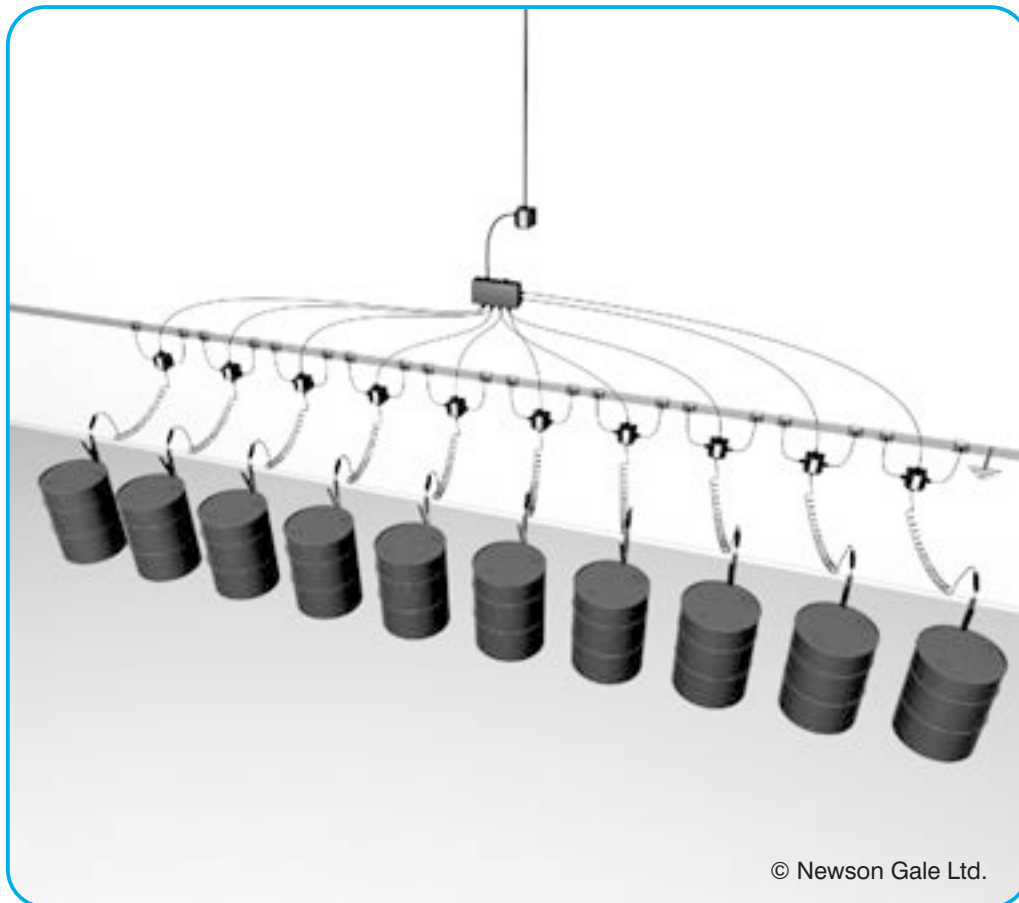

© Newson Gale Ltd.

Battery-powered self-testing clamps are suitable where they are not expected to be attached to plant items for prolonged periods. If continuous monitoring is required, such as in a drum store where product is regularly tapped-off from the drums, mains / line powered self-testing clamps with “remote” indicator stations are recommended.

CLC/TR 50404 states:

“Cables for earthing movable items should be equipped with a strong clamp capable of penetrating through paint or rust layers”. (11.4.1)

10 ohms is stated as a suitable value of resistance for monitoring static grounding circuits (CLC/TR 50404 - 11.2.2).

NFPA 77 states:

“In bonding and grounding installations that are prone to corrosion, movement, or insulating surface coatings, self-testing bonding clamps and systems can be used to continuously test the resistance to ground and verify acceptable results.” (6.8.4)

Grounding Mobile Vessels and Small Containers

Using self-testing clamps and cables

If additional information on the solution(s) illustrated is required contact Newson Gale or your local Newson Gale supplier and quote the Issue number of the Handbook and the page number on which the product is illustrated. Both numbers are located at the bottom of each Application page.



Bond-Rite REMOTE (SDP enclosure) with Stainless Steel Heavy Duty Clamp.
BRRPEB2A1- IECEx/ATEX
BRRPUB2A1- North America



Bond-Rite REMOTE (Stainless Steel enclosure) with Stainless Steel Heavy Duty Clamp.
BRRMEB2A1- IECEx/ATEX
BRRMUB2A1- North America

In some applications, such as those found in the paints and coatings industry, the benefits of a self-testing clamp are clear, enabling the operator to ensure that the clamp has penetrated through accumulated layers of product. However, it is possible that the LED on the clamp may become obscured by product splashing. In these situations, a self-testing clamp with a “remote” indicator LED and battery, mounted on the wall, will provide a suitable alternative.

A second benefit is that other, smaller clamps may be used with the monitoring unit, as dictated by the application.

BS 5958 states that when mixing and blending:

“All metallic parts of the equipment should be connected together and earthed so that the resistance to earth at all points is less than 10 ohms”. (10.2.1).

NFPA 77 states:

“In bonding and grounding installations that are prone to corrosion, movement, or insulating surface coatings, self-testing bonding clamps and systems can be used to continuously test the resistance to ground and verify acceptable results.” (6.8.4)

“Trans-Loading” Road Tanker/Railcar transfers to IBC/Tote/Drum

Using a ground monitoring system and portable bonding assembly

If additional information on the solution(s) illustrated is required contact Newson Gale or your local Newson Gale supplier and quote the Issue number of the Handbook and the page number on which the product is illustrated. Both numbers are located at the bottom of each Application page.



Earth-Rite RTR Tri-Mode with Tanker Truck Recognition.
RTRMEA1A3A - IECEX/ATEX
RTRMUA1A3A - North America



Bond-Rite EZ
BREZ05/IPX90 - IECEX/ATEX
BREZ05/IPX90 - North America

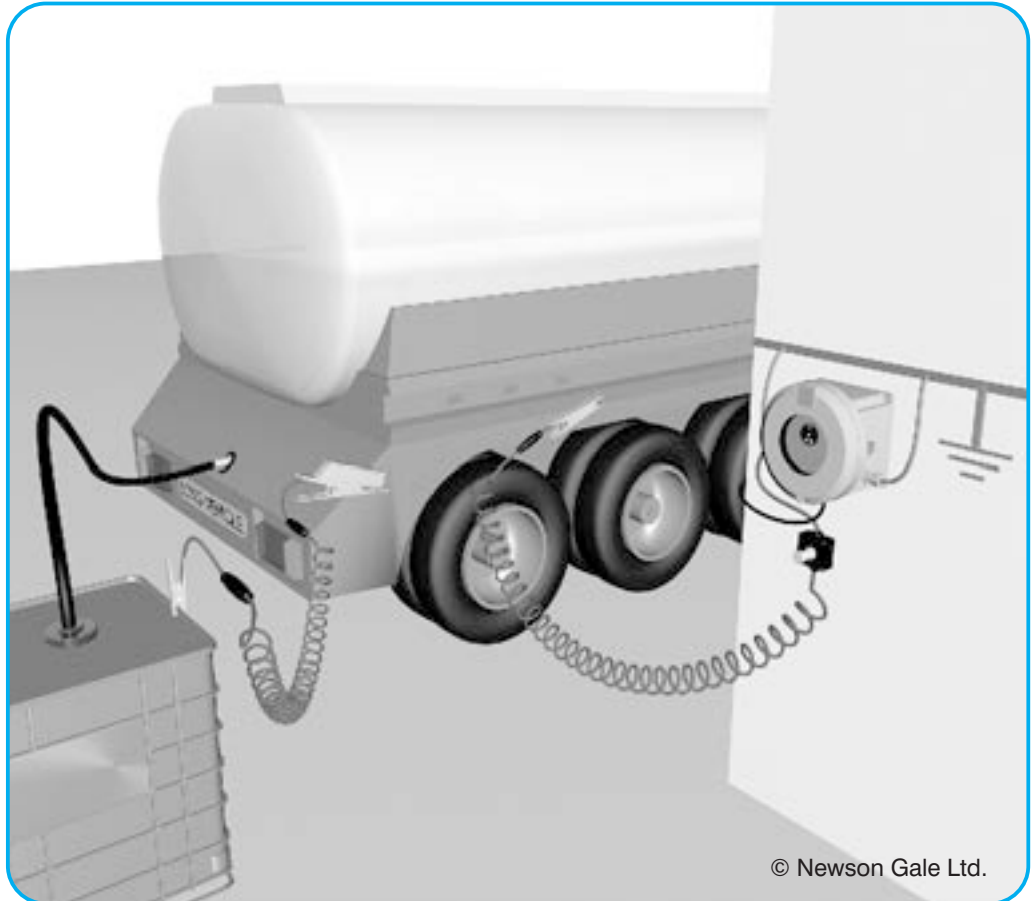

© Newson Gale Ltd.

The concept of "just-in-time" and lean inventory management principles have led some organizations in the chemical distribution sector to "Trans-Load" liquids directly from Bulk Tankers (Tank Trucks or Railcars) to Non-Bulk Containers (IBC's, Totes and Drums). When the liquids being transferred are flammable or combustible, the recommendations for grounding and bonding to prevent uncontrolled electrostatic discharge must always be followed. However as there are now two elements to bond and ground, a different approach is called for.

For a fixed installation one approach may be to monitor the connection to both the bulk tanker (tank truck/railcar) and the non-bulk container (IBC, Tote, Drum), then complete the "ground loop" via a bonding connection between both objects. This way both items are part of an equipotentially bonded and grounded circuit.

Alternatively, a ground verification system (e.g. Earth-Rite RTR) can monitor the primary ground connection to the bulk tanker, while a portable bond verification device (Bond-Rite EZ) is used to monitor the bond between the bulk tanker and the smaller container (IBC, Tote, Drum).

NFPA 77 describes the concept of mixing Bonding and Grounding techniques, and these are applicable to Trans-Loading operations when handling flammable and combustible materials.

NFPA 77 states:

"A conductive object can be grounded by a direct conductive path to earth, or by bonding it to another conductive object that is already connected to the ground." (7.4.1.1)

Grounding Drums and Containers

Using hazardous area approved grounding clamps and cables

If additional information on the solution(s) illustrated is required contact Newson Gale or your local Newson Gale supplier and quote the Issue number of the Handbook and the page number on which the product is illustrated. Both numbers are located at the bottom of each Application page.

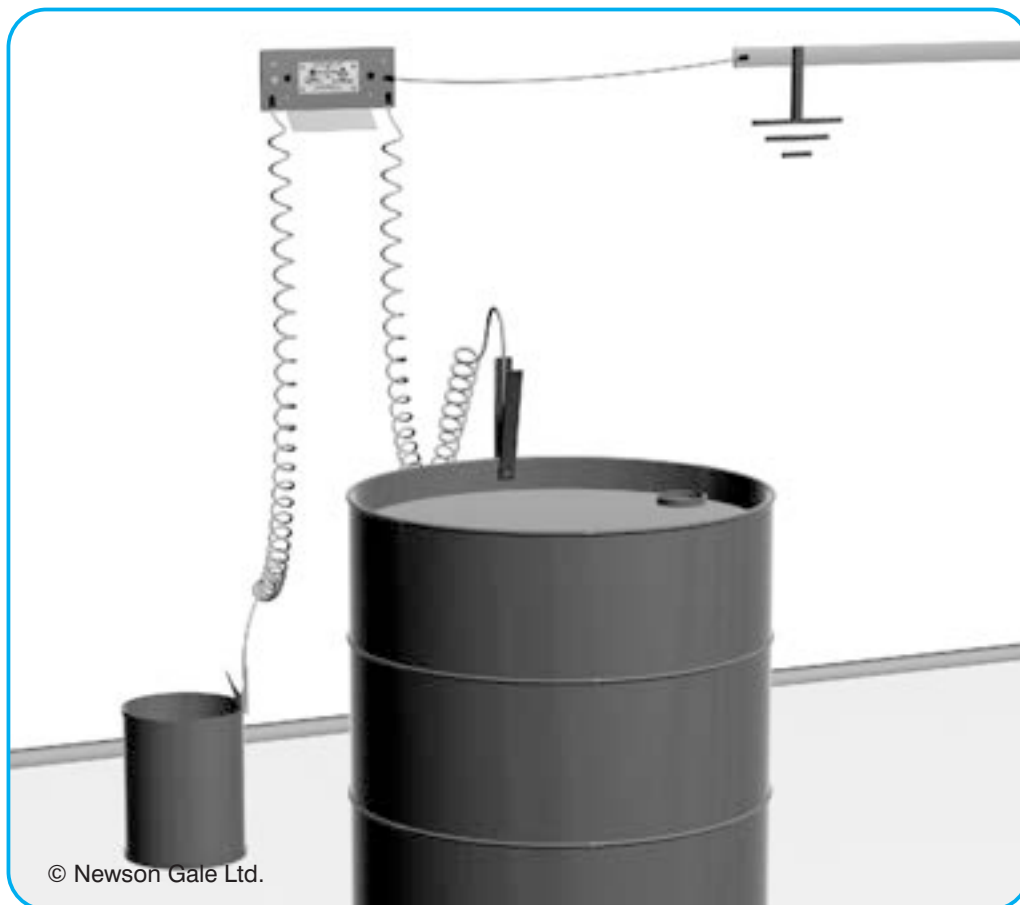

Cen-Stat™ Stainless Steel Clamp
& 3 mtr. (10 ft.) retractable cable
VESX45/1G03



Grounding Station
for clamp stowage (x2)
GS/E - IECEX/ ATEX
GS/U - North America

Movable metal items may be connected to ground via the bonding bar using the type of clamps and cables illustrated. The clamp should be designed to grip the container securely and to bite through any paint or rust layers. As a mechanical device, it should be approved for the Zone or Class/Division area in which it is utilised.

Grounding stations provide a convenient way of stowing clamps with retractable spiral cable and allow greater flexibility in positioning clamps at various locations on the site as the grounding stations themselves can be bonded to the nearest designated earth grounding point.

Cable conductors and their connections should be strong enough to avoid damage from repeated movement as the clamp is brought to and from the container.

In accordance with IEC recommendations, static grounding cables should be colour coded to differentiate their function to cable that is used for electrical bonding and earthing protection. For Europe, green colour coded cable applies for static grounding purposes. Orange coloured cable applies for North America.

CLC/TR 50404 states:

“There are items of equipment such as drums, funnels and trolleys, which cannot be permanently connected to earth through the main plant structure....To allow for this suitable temporary earthing connections should be used”. (11.3.1.2).

Grounding Drums and Containers with Storage Rack

Using hazardous area approved grounding clamps and cables

If additional information on the solution(s) illustrated is required contact Newson Gale or your local Newson Gale supplier and quote the Issue number of the Handbook and the page number on which the product is illustrated. Both numbers are located at the bottom of each Application page.



Cen-Stat™ Medium Duty
Stainless Steel Clamp
& 5 mtr. (16 ft.) retractable cable
VESX45/1G05



C clamp & Cen-Stat™ straight cable
VESC41/1GS01

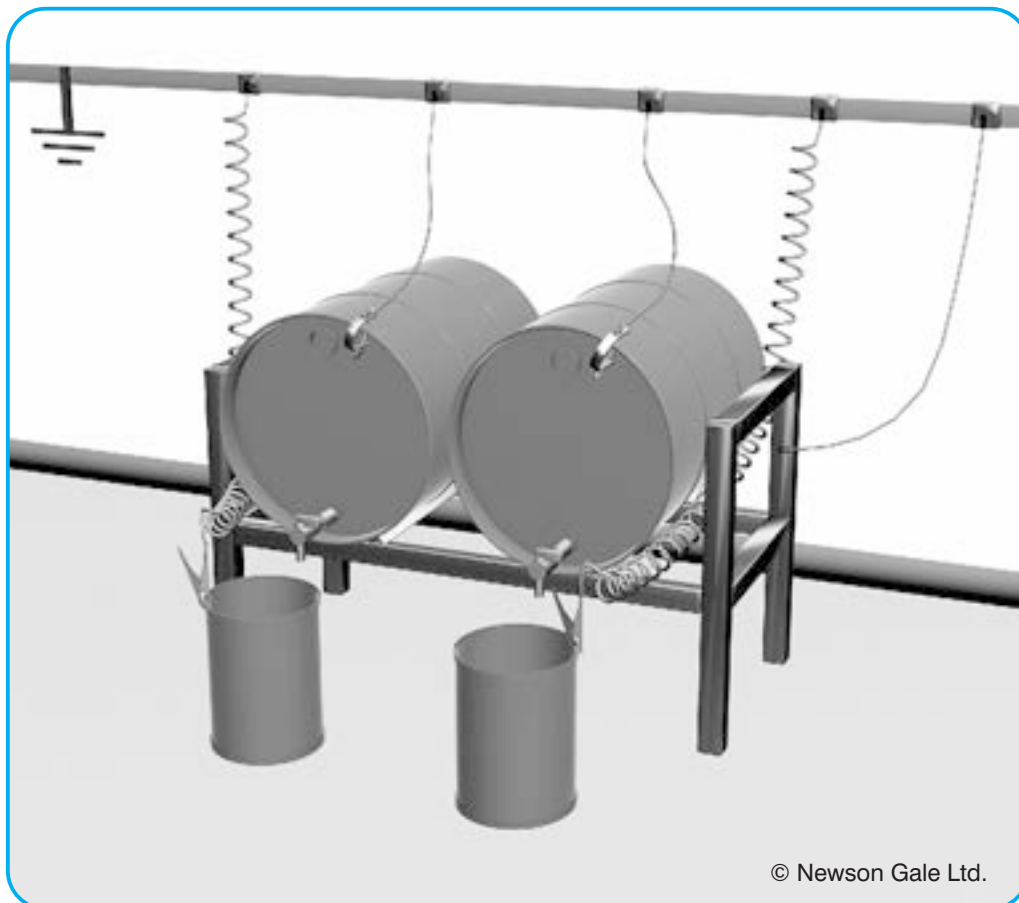

© Newson Gale Ltd.

When product transfer occurs, it is important to ensure that the containers involved are at ground potential (0 Volts). This can be achieved by grounding them using clamps and cables which go back to a common grounding bar, as shown. An alternative method is shown on page 21.

NFPA 77 states:

"Bonding should be done with a clamp having hardened steel points that will penetrate paint, corrosion products and accumulated material using either screw force or a strong spring". (8.13.3.2)

Bonding and Grounding Mobile Vessels and Small Containers

Using hazardous area approved grounding clamps and cables

If additional information on the solution(s) illustrated is required contact Newson Gale or your local Newson Gale supplier and quote the Issue number of the Handbook and the page number on which the product is illustrated. Both numbers are located at the bottom of each Application page.

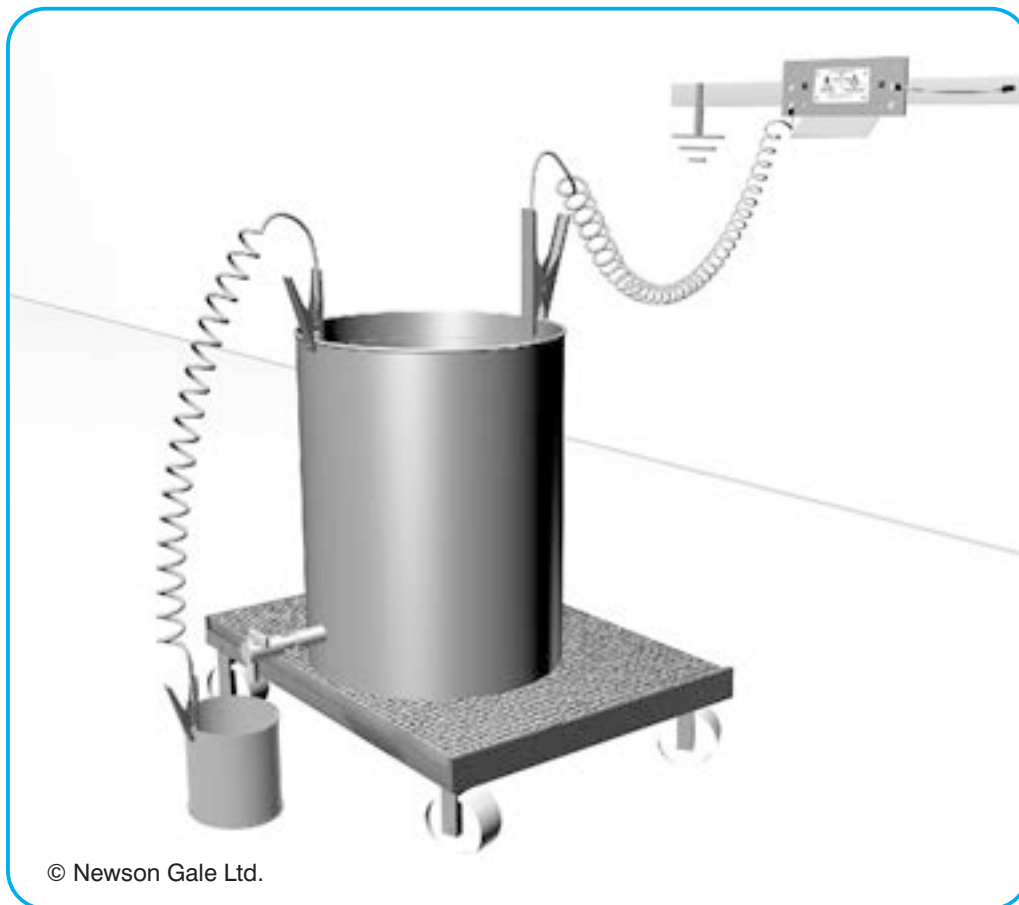

Cen-Stat™ Stainless Steel Clamp
& 3 mtr. (10 ft.) retractable cable
VESX45/1G03/X45



Cen-Stat™ Stainless Steel Heavy
Duty Clamp & 5 mtr. (16ft.)
retractable cable
VESX90/1G05

Ground potential (0 Volts) may be achieved on two vessels by connecting the main one to the grounding point and bonding the secondary container to the first, as shown. ATEX and FM certified stainless steel clamps are recommended for pharmaceutical / clean room applications or where high corrosion resistance is required.

NFPA 77 states:

*“When being filled, metal containers and associated fill equipment should be bonded together and grounded.”
(8.13.3.1)*

Grounding IBCs and Containers

Using hazardous area approved grounding clamps and reels

If additional information on the solution(s) illustrated is required contact Newson Gale or your local Newson Gale supplier and quote the Issue number of the Handbook and the page number on which the product is illustrated. Both numbers are located at the bottom of each Application page.



Cen-Stat™ VESX90 Stainless Steel Heavy Duty Clamp c/w 15.2 mtr. (50 ft.) self-retracting reel. VESX90/R50



Cen-Stat™ VESX45 Stainless Steel Clamp c/w 6.1 mtr. (20 ft.) self-retracting reel. VESX45/R20

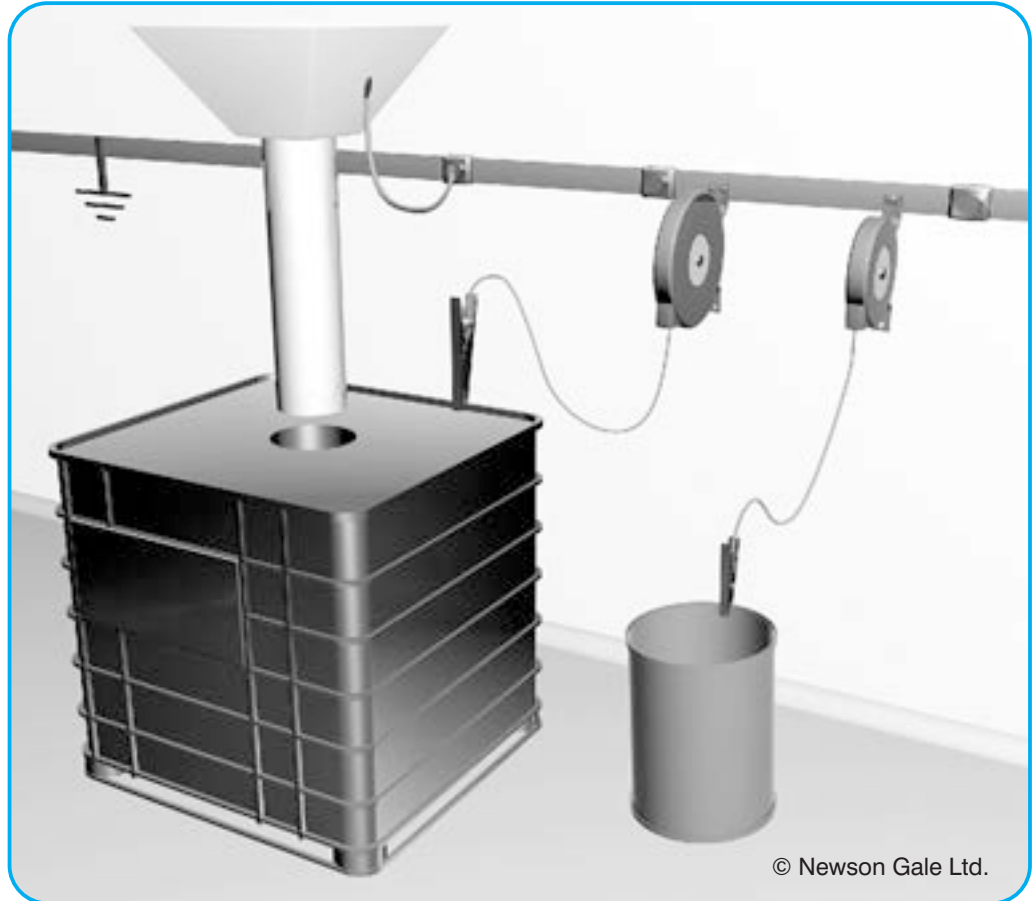

© Newson Gale Ltd.

As an alternative to spiral cables, self-retracting cable reels are a popular method of providing a reliable bond from the grounding bar to an IBC (intermediate bulk container) or other container type. The choice between spiral cables or retractable reels is down to practicality, convenience and user preference, as both are equally effective grounding devices.

BS 5958 states:

“During both filling and emptying, the container and all metallic parts of the system, such as funnels and nozzles, should be bonded together and / or earthed.” (11.2.1).

Grounding Personnel and Testing Condition of Footwear

Using static-dissipative footwear / footwear tester

If additional information on the solution(s) illustrated is required contact Newson Gale or your local Newson Gale supplier and quote the Issue number of the Handbook and the page number on which the product is illustrated. Both numbers are located at the bottom of each Application page.

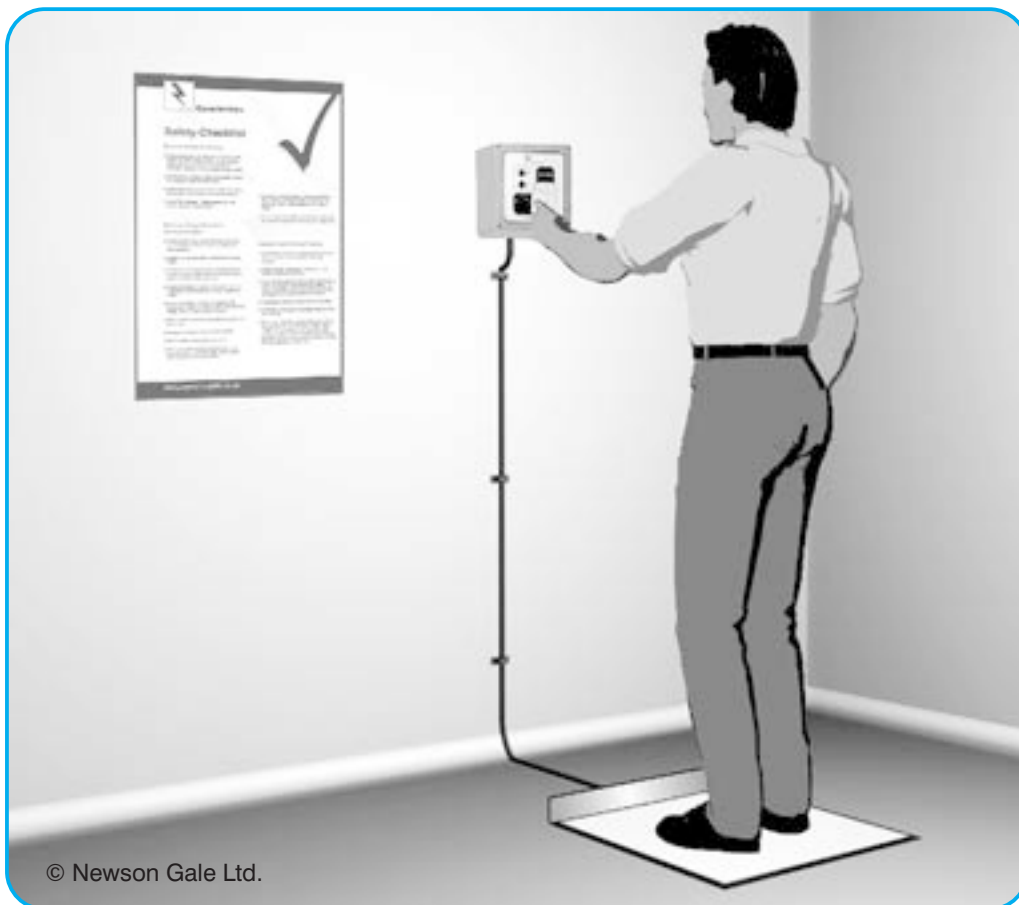

© Newson Gale Ltd.



Sole-Mate Footwear Tester
SM2/108/E - 1×10^8 ohm Tester
SM2/109/E - 1×10^9 ohm Tester

As with plant, it is equally important to ensure that personnel in hazardous areas are suitably grounded at all times. The most practical way to achieve this is to ensure that static dissipative footwear is worn and that floors have a suitable level of conductivity.

Several international standards and guidelines are in use to determine the correct resistance levels for Static Dissipative (SD) Footwear. Safety Footwear Standard EN ISO 20345 recommends a maximum resistance of 1×10^9 ohms, while CLC/TR 50404, ASTM-F2413-05 and BS 5958 all prescribe 1×10^8 Ohms.

In order to comply with the recommendations, a footwear tester should be used. It is vital to ensure that the tester selected monitors to the same level as the footwear in use on site. Testers monitoring to the levels recommended for use in the electronics industry (ESD) should not be used for testing the integrity of EN ISO 20345 or ASTM-F2413-05 footwear.

EN ISO 20345 states:

"The Footwear should normally have an electrical resistance of less than 1000 megohm (1×10^9 ohms) at any time throughout its useful life. The user is recommended to establish an in-house test for electrical resistance and use it at regular and frequent intervals" (7.2)

Guide to protection concepts and codes for electrical equipment operating in hazardous areas

Electrical Protection Method	Symbols	IECEX Code	IECEX Equipment Protection Level	Zone
Equipment protection by flameproof enclosures 'd'	d	60079-1	Gb	1, 2
Equipment protection by pressurized enclosures 'p'	px, py, pz	60079-2	Gb, Gc	1, 2
Equipment protection by powder filling 'q'	q	60079-5	Gb	1, 2
Equipment protection by oil immersion 'o'	o	60079-6	Gb	1, 2
Equipment protection by increased safety 'e'	e	60079-7	Gb	1, 2
Equipment protection by intrinsic safety 'i'	ia, ib, ic	60079-11	Ga, Gb, Gc	0, 1, 2
Equipment protection by type of protection 'n'	nA, nC, nR, nZ	60079-15	Gc	2
Equipment protection by encapsulation 'm'	ma, mb, mc	60079-18	Ga, Gb, Gc	0, 1, 2
Dust Protection Method (for electrical circuits)				
Enclosure	ta, tb, tc	60079-31	Da, Db, Dc	20, 21, 22
Intrinsic Safety	ia, ib, ic	60079-11	Da, Db, Dc	20, 21, 22
Encapsulation	ma, mb, mc	60079-18	Da, Db, Dc	20, 21, 22

NOTE: It is always important to ensure that electrical equipment specified for use in a hazardous area is certified to the requirements of current, and up to date, standards and codes. Specifiers must ensure that the location for which the equipment is specified matches the protection levels required for the particular zoned / classified area.

The codes used in the above table are based on IECEx standards of classification. However, the protection concepts are generally recognised by ATEX, the National Electrical Code and Canadian Electrical Code. Note that these standards are continuously updated, therefore, protection concepts or code descriptions may be revised or removed.

Temperature Classification of electrical equipment

Hazardous materials are classed by their auto-ignition temperature and the "T" rating is the maximum surface temperature that the certified equipment can reach.

Temperature Class

(IECEX, ATEX, NEC 505, CEC S.18).

T1	450°C
T2	300°C
T3	200°C
T4	135°C
T5	100°C
T6	85°C

Temperature Class (NEC 500, CEC Annex J)

T1	450°C				
T2	300°C	T2A 280°C	T2B 260°C	T2C 230°C	T2D 215°C
T3	200°C	T3A 180°C	T3B 165°C	T3C 160°C	
T4	135°C	T4A 120°C			
T5	100°C				
T6	85°C				

Note that equipment approved for use in Gas or Gas and Dust zones usually has the temperature rating expressed as the T Class (e.g. T6), however equipment approved for use in Dust zones only, usually shows the actual temperature (e.g. T85°C).

Ingress Protection

It is generally accepted that ingress protection for Ex equipment starts at IP54:

IP54	protection against dust and water splashed from any direction (inc. rain)
IP55	protection against dust and low pressure water jets / hosing
IP65	completely dust tight and protected against low pressure water jets / hosing
IP66	completely dust tight and protected against heavy seas
IP67	completely dust tight and protected against periods of immersion in water

The American NEMA ingress ratings are difficult to equate to the IEC IP ratings, but the commonly specified NEMA 4 and 4X ratings cover Ingress Protection levels up to IP 66. NEMA 4X enclosures have additional protection against corrosion.

Comparison of European (ATEX), North American (NEC & CEC) and International (IECEx) Hazardous Area Classification Systems.

	Combustible atmospheres present continuously, for long periods or frequently	Combustible atmospheres are likely to occur in normal operation	Combustible atmospheres are unlikely to occur, be present infrequently or for short periods only
IECEx / ATEX (Gas & Vapour)	ZONE 0	ZONE 1	ZONE 2
IECEx / ATEX (Dust)	ZONE 20	ZONE 21	ZONE 22
NEC 505 / CEC S.18 Class I	ZONE 0	ZONE 1	ZONE 2
NEC 506 Class II (Dust)	ZONE 20	ZONE 21	ZONE 22
	Combustible atmospheres can exist all of the time or some of the time under normal operating conditions		Combustible atmospheres are not likely to exist under normal operating conditions
NEC 500 / CEC Annex J Class I (Gas) Class II (Dust) Class III (Fibres)	Division 1		Division 2

Two classification systems are used in the U.S. and Canada. For the U.S. NEC 500 (Class / Division) and NEC 505 / NEC 506 (Class / Zone) apply. In Canada, CEC Section 18 describes the Class / Zoning system (Class I only) and CEC Annex J describes the Class / Division method. The zoning system of the NEC and CEC standards is similar to the IECEx / ATEX method of zoning.

Comparison of European and North American Gas (and Dust) Groups

Groups according to IECEx, ATEX, NEC 505, CEC S.18	
Gas Group	Representative Gas
I (Mining)	Methane
IIA	Propane
IIB	Ethylene
IIC	Hydrogen

Groups according to NEC 500 & CEC Annex J					
Group		Representative Gas	Group		Representative Dust / Fibre
Class I	Group A	Acetylene	Class II	Group E	Metal Dust
Class I	Group B	Hydrogen	Class II	Group F	Coal Dust
Class I	Group C	Ethylene	Class II	Group G	Grain Dust
Class I	Group D	Propane	Class III		Fibres

Interpreting certification and approval codes for hazardous area electrical equipment.

The codes provided below are examples of the wide range of approvals / certifications required for hazardous area electrical equipment. The codes reflect current **ATEX**, **IECEX**, **NEC** and **CEC** methods of certification and approval.

The hazardous area codes for the Earth-Rite RTR are used to illustrate the differences and similarities between these methods.

North American approvals to NEC 500 & CEC Annex J requirements for the Earth-Rite RTR

“Class I”: Combustible liquid, gas and vapour atmosphere

“Div.1”: Division 1 defined as a location where combustible atmospheres can exist under normal operation, during maintenance, due to leaks or when equipment is faulty.

Class I, Div. 1, Groups A, B, C, D.

“Groups A, B, C, D”: Indicates which gas groups the grounding system can be installed in. Gases, vapours, liquids are grouped according to their Minimum Experimental Safety Gap and Minimum Ignition Current ratio characteristics. Higher Groups (e.g. A and B) require high levels of flameproof protection and low energy current.

“Class II”: Combustible Dust atmospheres.

“Div.1”: Division 1 defined as a location where ignitable dusts are normally suspended in air at a potentially combustible value under normal operating conditions.

Class II, Div. 1, Groups E, F, G.

“Groups E, F, G”: Group E represents conductive metal dusts (e.g. aluminium). Group F represents carbonaceous dusts (e.g. coal dust). Group G represents other dust types not included in E and F, including the likes of grain, starch, flour, plastics and chemicals (pharmaceutical).

Class III, Div. 1

Hazardous locations where easily ignitable fibres and flyings are present around machinery but are not likely to be suspended in the atmosphere. Examples include saw dust from cutting operations and textile mills

Please note that NEC 505 & NEC 506 and CEC Section 18 describe the Class and Zoning system of hazardous location classification. If you require more information on grounding and bonding systems that must be approved to this method of classification please contact Newson Gale or your local Newson Gale supplier who can provide you with appropriate Certificates of Compliance.

ATEX certification for the Earth-Rite RTR

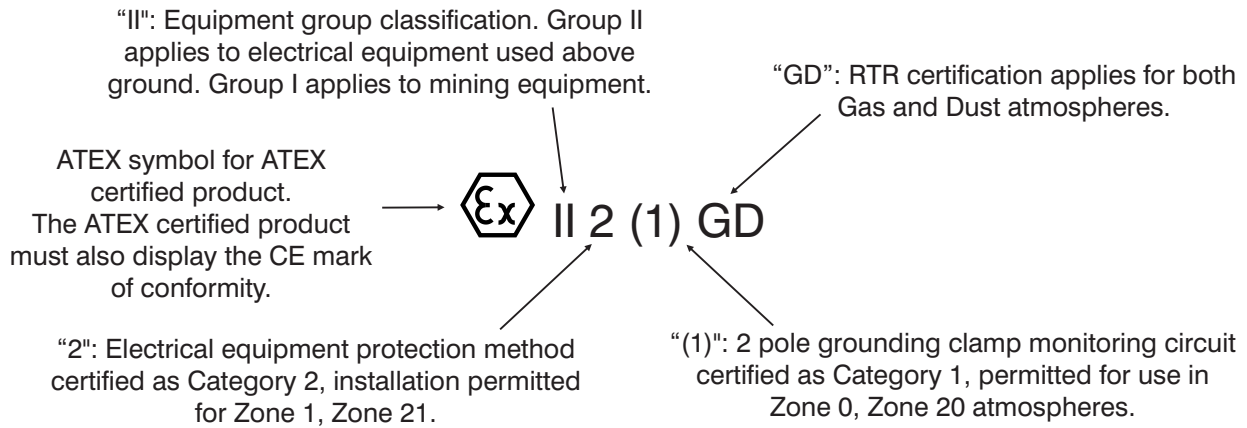

IECEx certification (Gas & Vapour atmospheres) for the Earth-Rite RTR

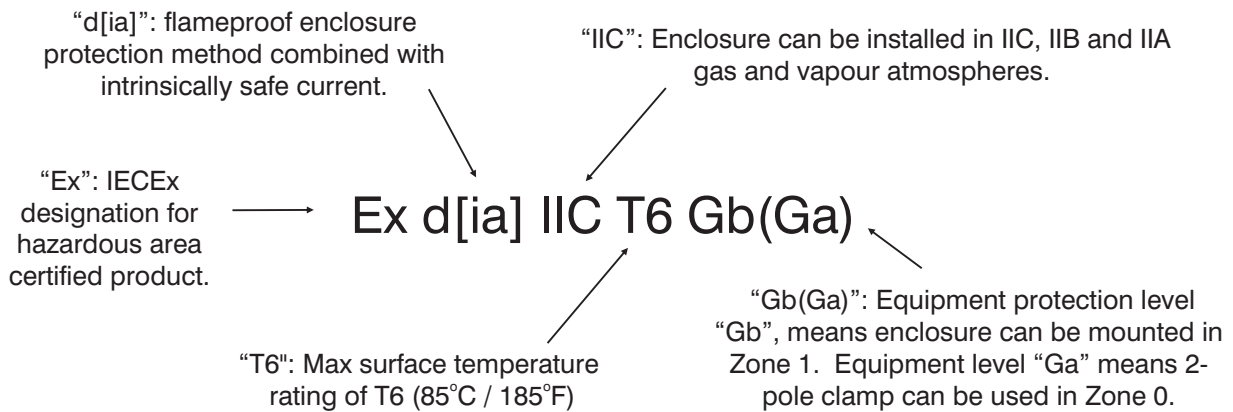

IECEx certification (Dust atmospheres) for the Earth-Rite RTR

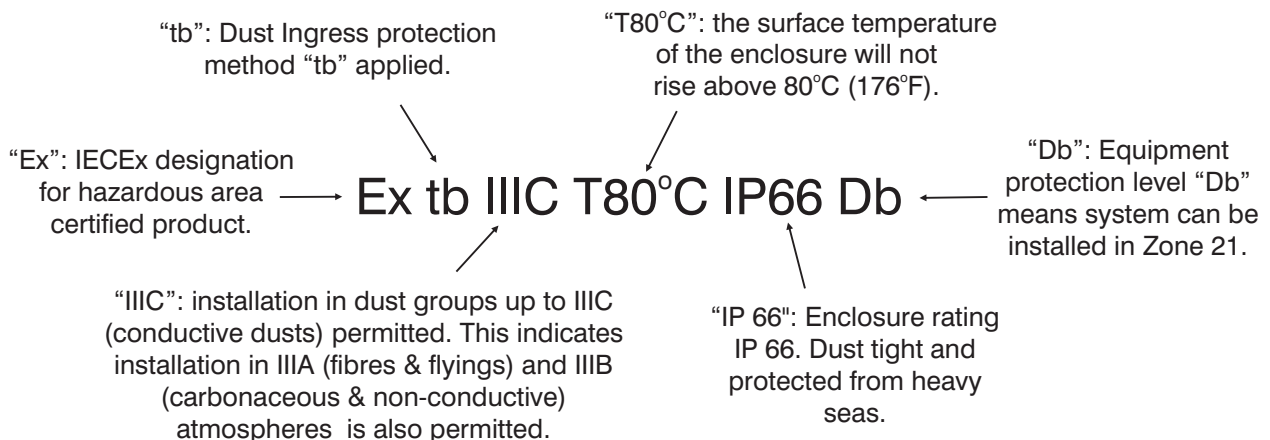

On-Going Maintenance of Static Control Procedures and Equipment

Once appropriate static control procedures and equipment have been put in place, it is vital that a high level of static awareness is maintained. The three principles of a successful, on-going static control policy are:

- i. Regular testing of the equipment used including logging of results.
- ii. Frequent awareness training for operators and staff, particularly new employees.
- iii. Reference to the standards when changes take place, such as the introduction of new types of plant or materials.

Generally, there are two main elements to the physical side of the static grounding system. These are firstly, the fixed grounding network. This may take the form of a copper strip or bar running along the walls and connected to a number of grounding rods, pits or grids, driven into the ground. This network should be tested periodically, with respect to ground, to ensure that it is maintaining a low (typically less than 10 ohm) resistance to ground. These tests are fairly specialist, and may be carried out by an outside contractor, often in conjunction with tests on lightning protection equipment. A typical test period would be every 11 or 13 months (so that over a period of time, the tests cycle through the seasons). A main point to look out for when testing the network, is any significant variation with previous tests, which could show deterioration. This also highlights the need for keeping good records. If the grounding network meets the necessary low resistance, then any metal object connected to it will also be grounded.

The second part of the physical system is the devices used to connect plant and equipment to the grounding network. If a piece of plant is fixed, such as the body of a mixing machine, then a simple strong bonding cable can be used to permanently attach it to the grounding network. However, movable plant, such as the mixer's product bowl, or a 200 litre drum is harder to ground, and the standards recommend that a cable with strong mechanical strength and a "designed for purpose" clamp are used to make a temporary connection when the item is in use. These connections can be tested using an intrinsically safe ground lead tester or ohm meter and the results for each lead recorded. The tester or meter will be used to complete a circuit between the grounding point and the plant item to be grounded; for the purpose of testing clamps and their cables or reels, this may take the form of a clean piece of metal placed in the clamp jaw. The tester or meter leads may then be connected between the piece of metal and the grounding point in order to complete the circuit and obtain a reading.

These types of flexible connector should be tested more frequently than fixed ones; typically once every three months in the case of ground leads and after every re-assembly, in the case of bonds on removable ducting sections. A bond to a fixed piece of plant may be tested on an annual or six-monthly basis.

The on-going training of personnel may be more difficult to maintain, partly because of disruption to production, and also, as it can be difficult to keep things interesting. Training today need not just take the form of a classroom lecture; new learning media such as interactive CD-ROM provides flexible training solutions to accommodate the varying needs of production schedules, shifts and locations. Team leaders can quickly assess the knowledge level of existing or new operators and programme one or two hours per week to bring knowledge levels up.

Today, it is common for companies to use continuous monitoring of ground connections and systems incorporating interlocks that prevent a static-generating operation from taking place unless the ground is made. Such systems mean that the frequency of lead testing can be reduced, as the systems are providing a continuous test to a pre-determined resistance level. They also mean that the grounding measures are more likely to be remembered during operation, as a visual indication of ground condition, such as the LED in a self-testing clamp, act as a strong reminder to use the device

EARTH-SAFE™

EARTH-SAFE™ is a Newson Gale service that ensures all earth grounds used onsite are functioning in accordance with current standards. Very often, the connection resistance to True earth of earth ground electrodes are overlooked and not tested on a regular basis to ensure they are functioning correctly. With this service, sites can be sure that their static grounding and bonding equipment is connected to earth ground electrodes that will reliably dissipate static electricity from equipment at risk of static charge accumulation.

EARTH-SAFE™ is a trademark of Newson Gale.

Typical time intervals between tests:	
Fixed earthing	Every 11 or 13 months
Fixed plant and equipment	Annually
Earth Monitoring systems and devices	Annually
Non-monitored earthing leads and clamps	Every 3 months
Removable plant sections	After every re-assembly
Footwear	Weekly or daily, depending on conditions

This information is intended for guidance only, as every situation is different and suitable periods between tests may vary depending on individual plant, processes, etc. Of course, any defects in grounding and bonding devices, noticed by staff between maintenance periods, should be reported immediately.

Safety-Checklist

Maximise Safety in the Area

- Ensure all operators and managers are trained in safe working with flammable products. It is vital that they understand the characteristics and dangers of flammable products and the principles of static control.
- Ensure all electrical equipment is appropriate for use in the designated flammable atmosphere.
- Ensure lift trucks and other vehicles used in the vicinity are explosion protected to the appropriate standard.
- Ensure “**No Smoking**”, “**Static Hazard**” and “**Ex**” warning signs are clearly posted.

Minimise Charge Generation and Accumulation

- Ensure operators are supplied with static-dissipative (S.D.) footwear. Gloves, if worn, should also be static-dissipative.
- Ensure floors are adequately conductive and are well grounded.
- Ensure static-dissipative footwear is always worn and remains in good condition by use of resistance testing before entry into the combustible area.
- Ensure all containers, pipework, hoses, plant, etc., are conductive or static-dissipative, bonded together and grounded.
- Ensure that sufficient, suitable grounding leads and clamps are provided to enable movable containers to be grounded prior to product transfer or mixing.
- Where practical, pipe liquids directly from storage to the point of use.
- Eliminate or minimise product free-fall distances.
- Where practical, keep pumping speeds low.
- When using plastic materials, such as drums, kegs, liners and hoses in combustible areas, they should be static-dissipative and suitably grounded.

- When using FIBCs (Big Bags) in combustible areas or with potentially combustible dusts or powders, they should be “Type C” static-dissipative and suitably grounded.
- The use of anti-static additives should be considered in low conductivity liquids if they do not harm the product.

Maintain Safe Working Practices

- Ensure all new operators, managers and maintenance staff are trained in safe working with flammable products.
- Develop a written “safe system of working” for the handling of flammable products.
- Ensure all grounding straps, clamps, wires and monitoring systems are regularly inspected and maintained. The results of inspections should be recorded. Intrinsically safe equipment should be used to test continuity.
- Ensure static-dissipative floors remain non-insulating.
- Ensure all contractors are controlled by strict “permit-to-work” systems.
- Where large, conductive, movable equipment, such as stainless steel IBCs, road tankers or “Type C” FIBCs could become isolated from ground, the use of ground monitoring systems, with suitable interlocks to process equipment, pumps or valves is recommended, to ensure that they cannot pose a static hazard.



Newson Gale®

Leading the way in hazardous area static control



**ATEX &
FM approved
Retractable
Reel options
available**

5 Good Reasons To specify FM & ATEX approved clamps

Clamp Pressure Testing

Ensures the clamp is capable of establishing and maintaining low resistance electrical contact with equipment.

Electrical Continuity Testing

Ensuring the continuity from the tip throughout the clamp is less than 1 ohm.

High Frequency Vibration Testing

Ensures the clamp is capable of maintaining positive contact when attached to vibrating equipment.

Mechanical Pull Testing

Ensures the clamp cannot be pulled off the equipment without an intentional application of force.

No sources of Mechanical sparking

Ensures no mechanical sparking sources are present in the clamp.



Newson Gale Inc
460 Faraday Avenue
Bldg C
Jackson, NJ 08527
USA

Tel: +1 732 961 7610
Fax: +1 732 791 2182
Email: groundit@newson-gale.com



Newson Gale Ltd
Omega House
Private Road 8
Colwick, Nottingham
NG4 2JX, UK

Tel: +44 (0)115 940 7500
Fax: +44 (0)115 940 7501
Email: groundit@newson-gale.co.uk



Newson Gale GmbH
Ruhrallee 185
45136
Essen
Deutschland

Tel: +49 (0)201 89 45 245
Fax: +49 (0)201 42 60 026
Email: erdung@newson-gale.de



Newson Gale S.E.A. Pte Ltd
No. 12 Little Road, #08-02
Lian Cheong Industrial Building
Singapore
536986

Tel: +65 6420 0443
Fax: +65 6725 0570
Email: ngsea@newson-gale.com

www.newson-gale.com

Copyright Newson Gale Ltd. Permission is granted to copy and circulate parts of this publication for internal training and educational use provided full acknowledgment of Newson Gale Ltd as its source is shown.